

## Part #800328

### REMOVAL

- (1) Remove and cap steering pump hoses and vacuum pump vacuum line.
- (2) Remove the oil pressure sender unit from engine block and plug hole in the block (Fig.5).
- (3) Remove the serpentine belt.
- (4) Remove and cap the oil feed line from the bottom of the vacuum pump (Fig. 6).
- (5) Remove the lower bolt that attaches the vacuum / steering pump assembly to the engine block. Remove the nut from the steering pump attaching bracket (Fig. 6).
- (6) Remove upper bolt from the pump assembly (Fig. 7) and remove the assembly.
- (7) Remove the mounting gasket.
- (8) Remove the steering pump to vacuum pump bracket attaching nuts (Fig. 8).
- (9) Slide the steering pump from the bracket. Use care not to damage the internal oil seal in the vacuum pump.

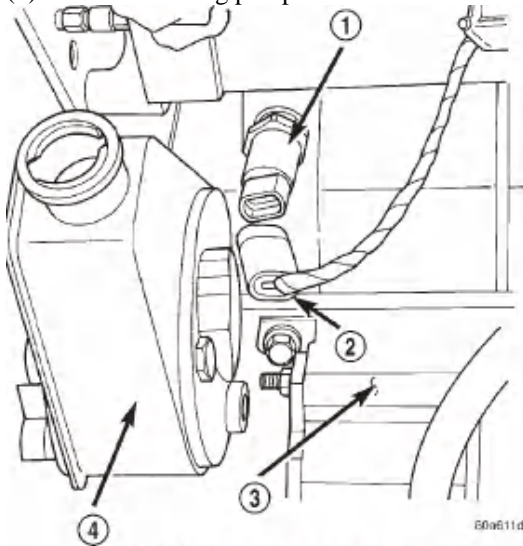

Fig. 5 Oil Pressure Sending Unit

- 1 - OIL PRESSURE SENDER UNIT
- 2 - ELECTRICAL CONNECTOR
- 3 - ENGINE BLOCK
- 4 - STEERING PUMP

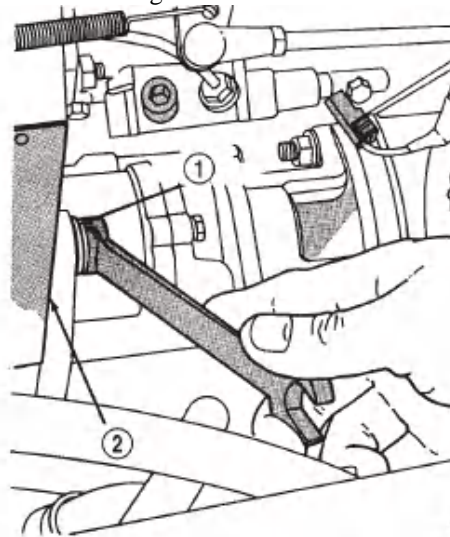

Fig. 7 Pump Assembly Upper Bolt

- 1 - PUMP UPPER BOLT
- 2 - DRIVE COVER

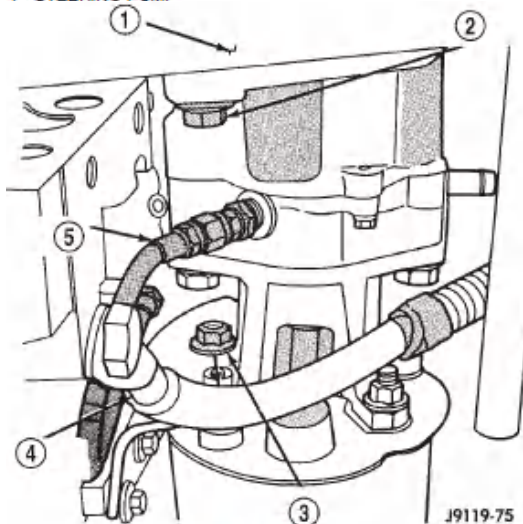

Fig. 6 Oil

J9119-75

- 1 - ENGINE BLOCK
- 2 - LOWER PUMP ASSEMBLY BOLT
- 3 - STEERING PUMP BRACKET ATTACHING NUT
- 4 - BATTERY GROUND CABLE
- 5 - OIL FEED LINE

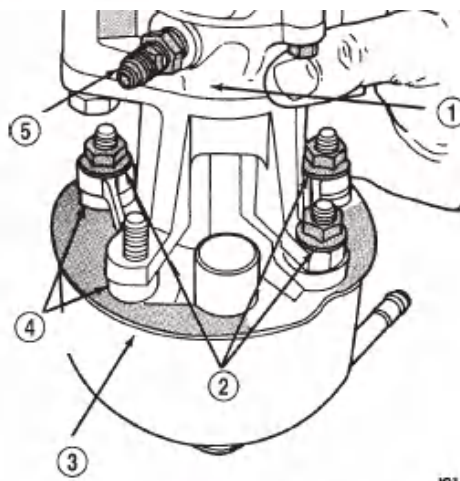

Fig. 8 Bracket Mounting Nuts

J911

- 1 - VACUUM PUMP
- 2 - ATTACHING NUTS
- 3 - STEERING PUMP
- 4 - PUMP SPACERS
- 5 - OIL FEED FITTING

## INSTALLATION

- (1) Install the two pump body spacers.
- (2) Rotate the drive gear until the steering pump and vacuum pump drive dogs align. Install the steering pump onto the vacuum pump bracket. Use care to avoid damaging the oil seal in the vacuum pump during installation. **The steering pump housing and spacers must mate completely with the vacuum pump bracket.**
- (3) Install the vacuum pump bracket to steering pump nuts and tighten to 18 ft. lbs.
- (4) Position gasket on vacuum pump assembly. Use sealer if necessary to retain the gasket.
- (5) Align and install the pump assembly on the engine. Ensure the steering pump stud is inserted into the block bracket. Tighten the pump- to-engine block attaching bolts to 57 ft. lbs.
- (6) Install the steering pump to attaching bracket nut and tighten to 18 ft. lbs.
- (7) Remove plug and install the oil pressure sending unit and electrical connector.
- (8) Install the oil feed line to the vacuum pump. Tighten the oil line connection snug +/- 5ft. lbs.
- (9) Install the fluid hoses to the power steering pump. Tighten the pressure fitting at the pump to 23 ft. lbs.
- (10) Install and clamp the hose on the vacuum pump.
- (11) Install the serpentine belt.
- (12) Fill the pump fluid reservoir to the proper level and let the fluid settle for at least two minutes. Raise the front wheels off the ground and slowly turn the steering wheel lock-to-lock 20 times with the engine off while checking the fluid level.
- (13) Lower the vehicle and start the engine. With the engine idling, be sure to maintain the proper fluid level. Turn the steering wheel in both directions and verify power assist and quiet operation of the pump. If the fluid is extremely foamy or milky looking, allow the vehicle to stand a few minutes and repeat this procedure.

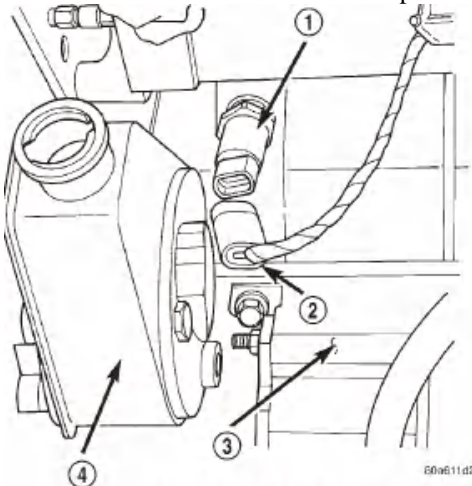

Fig. 5 Oil Pressure Sending Unit

- 1 - OIL PRESSURE SENDER UNIT
- 2 - ELECTRICAL CONNECTOR
- 3 - ENGINE BLOCK
- 4 - STEERING PUMP

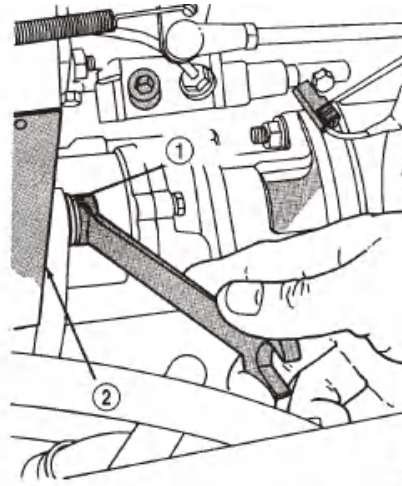

Fig. 7 Pump Assembly Upper Bolt

- 1 - PUMP UPPER BOLT
- 2 - DRIVE COVER

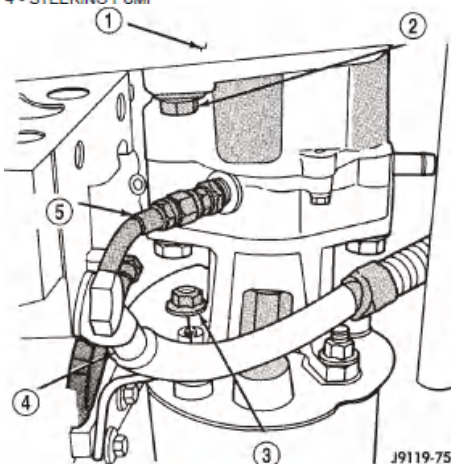

Fig. 6 Oil

- 1 - ENGINE BLOCK
- 2 - LOWER PUMP ASSEMBLY BOLT
- 3 - STEERING PUMP BRACKET ATTACHING NUT
- 4 - BATTERY GROUND CABLE
- 5 - OIL FEED LINE

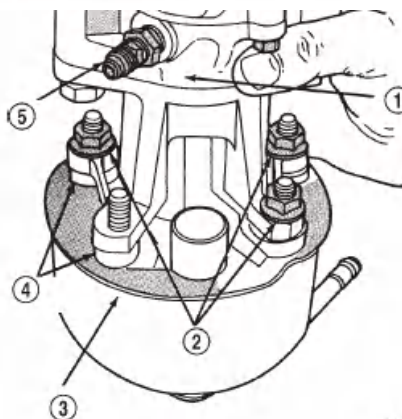

Fig. 8 Bracket Mounting Nuts

- 1 - VACUUM PUMP
- 2 - ATTACHING NUTS
- 3 - STEERING PUMP
- 4 - PUMP SPACERS
- 5 - OIL FEED FITTING