

Installation: Tapped Intake Manifold Bolts

DODGE Turbo Diesel Truck – All Years

DO NOT OVERTORQUE

Locate and remove one of the back (closest to the valve cover - see diagram) intake manifold bolts (#2). Choose the bolt that is easiest for you to access. Prior to installing your tapped intake manifold bolt, you should insert and tighten the 1/8" barbed fitting supplied with the Westach gauge or the 1/8" NPT compression fitting supplied with the ISSPRO and Auto Meter gauges.

NOTE:

When you tighten the compression nut, do not exceed the 12 ft./lbs. torque of the already installed tapped manifold bolt.

Next, install the tapped intake manifold bolt with the barbed fitting or compression fitting attached, and tighten to 12 ft./lbs. This is the same torque specification as the original intake manifold bolts.

Be careful not to exceed the specified torque. The tapped intake manifold bolt is hollow and bolt shear will occur. (This is the voice of experience talking to you.)

DO NOT OVERTORQUE

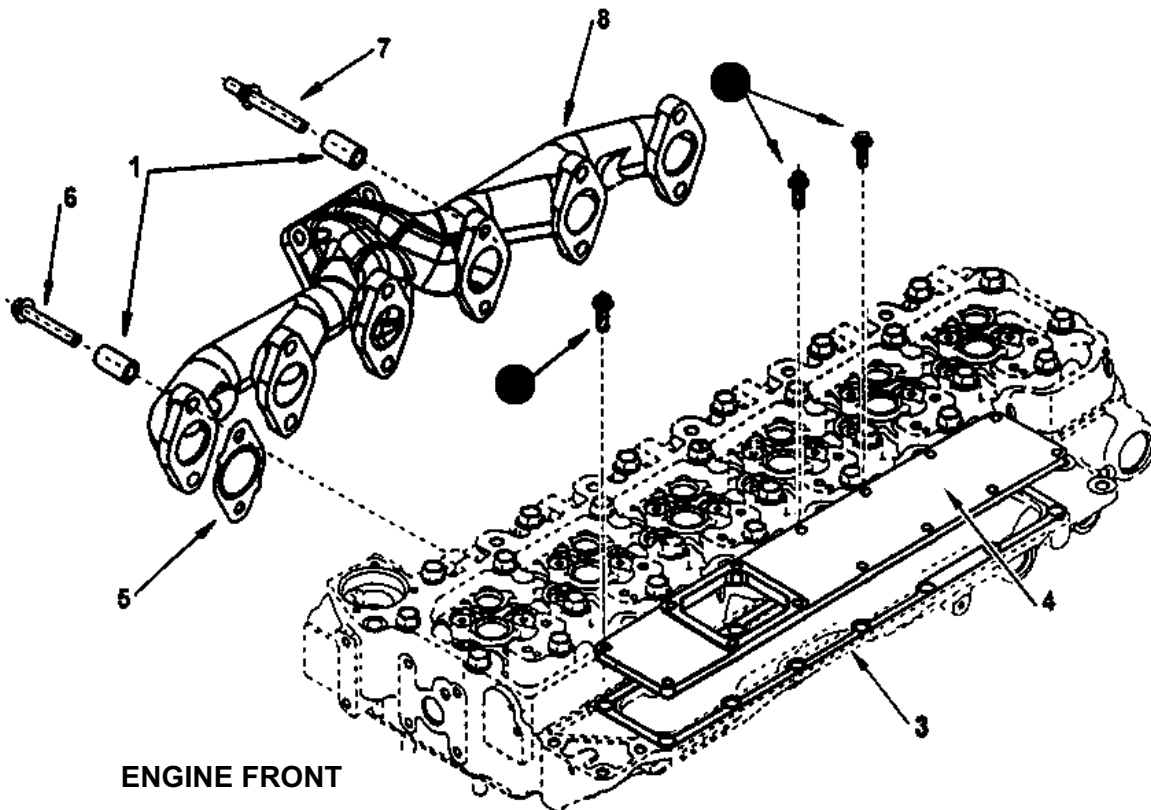

ENGINE FRONT

NOTE:

Diagram is of a 24-Valve, 5.9L, Cummins Turbo Diesel.
The 6.7L Cummins Turbo Diesel is similar to the 5.9L Cummins Turbo Diesel.



If you need more assistance, we are only a phone call away.

(770) 886-2500

Monday-Friday
8:30am-5:30pm EST

GENO'S GARAGE, INC.
1150 Samples Industrial Drive
Cumming, Georgia 30041