

Follow this procedure to adjust the fuel shutoff solenoid in your '94-'98, 12V Ram Cummins truck.

- 1) Turn the ignition to ON without bumping the starter.
- 2) Pull up the solenoid by hand, if the solenoid is working correctly it will hold itself up.
- 3) Before you remove the solenoid, measure from the bottom of the mounting bracket to the top of the shutdown lever. This measurement should be close to 2-5/8".

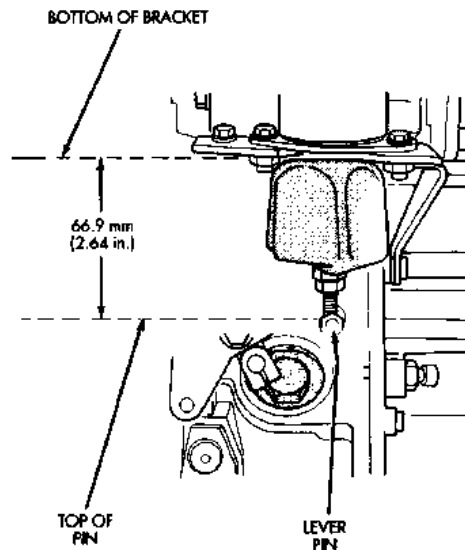

- 4) If the measurement is not 2.64 inches or 66.9mm (factory specifications), loosen the shaft locknut and rotate the shaft until it is 2.64 inches (Really 2.64, let's try 5/8" or 2.625).

Location of the Fuel Shutdown Relay

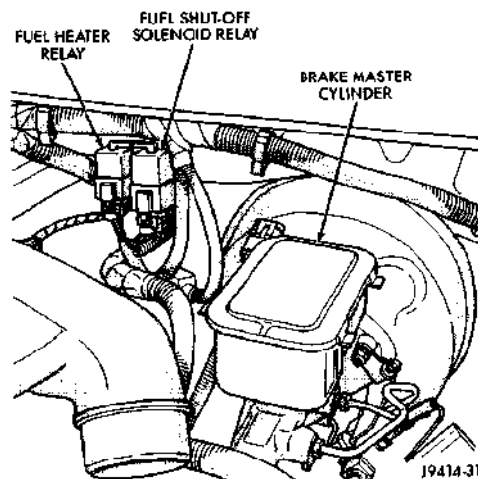

If you need more assistance, we are only a phone call away.

(770) 886-2500

Monday-Friday
8:30am-5:30pm EST

GENO'S GARAGE, INC.
1150 Samples Industrial Drive
Cumming, Georgia 30041

Should the fuel START/RUN solenoid fail to energize (come up) and/or hold in the “UP” position, do not let its malfunction leave you stranded.

Have an assistant attempt to start your truck while you move the solenoid’s plunger up to the “RUN” position. If it starts and the solenoid holds in the “RUN” position, drive it to your destination for further troubleshooting as time permits. If the solenoid fails to hold in the “RUN” position, tie-wrap it in the “RUN” position, and drive it to your destination. Cut the wrap, and the engine will stop.

So, we presented a tip to get you to a desired location. Does the problem lie with the solenoid, the relay to the solenoid, the fuseable link that feeds the solenoid or a fuse?

Do a voltage check at the solenoid’s three-wire connector. Negative goes to the Black/Red trace wire. On “START”, positive 12-volts will be at the Red/Black trace wire. (Item 1.)

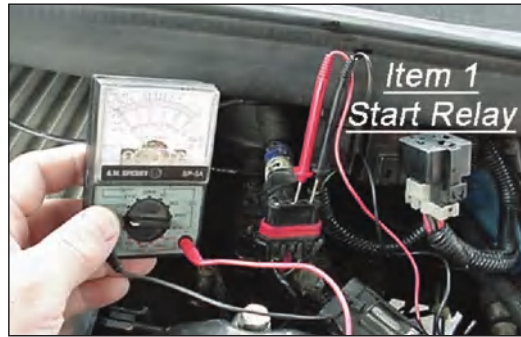

No voltage for “START” tells you to check the relay to the solenoid (Item 1).

If voltage is present for “START” the solenoid is likely the problem.



Also check the fuseable link that feeds the solenoid (Item 2) or fuse #9 in the fuse panel.

No voltage for “START”? Chances are that the solenoid is okay. Check the relay, fuseable link or fuse #9 as the source of the electrical malfunction. (Item 2.)